

Work station with optional suspended cabinet

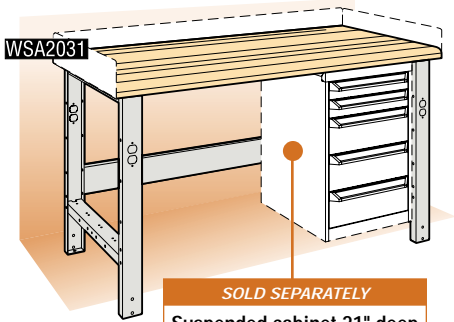

SOLD SEPARATELY
Suspended cabinet 21" deep
Model shown: WSA2031

SEE PAGE 12-13

Dimensions			Work area accessories	Type of top			
width	depth	height		Steel	Laminated wood	Plastic laminate	Wood composite
60"	30"	34"	None	WSA1031	WSA2031	WSA3031	WSA5031
			Back and side stops	WSA1032	WSA2032	WSA3032	WSA5032
72"	30"	34"	None	WSA1035	WSA2035	WSA3035	WSA5035
			Back and side stops	WSA1036	WSA2036	WSA3036	WSA5036
72"	36"	34"	None	WSA1039	WSA2039	WSA3039	WSA5039
			Back and side stops	WSA1040	WSA2040	WSA3040	WSA5040

Model including:
Your choice of top _____
Your choice of top accessories _____
2 legs 27"d × 32"h _____
1 stringer _____
Model number with the cabinet shown: WSC0108

Note: Mobile work stations are not available in this model.

Work station with optional drawer unit

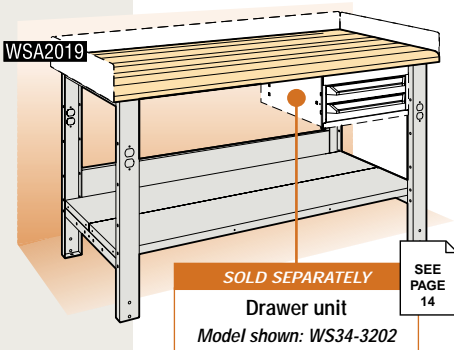

SOLD SEPARATELY
Drawer unit
Model shown: WSA2019

SEE PAGE 14

Dimensions			Work area accessories	Type of top			
width	depth	height		Steel	Laminated wood	Plastic laminate	Wood composite
60"	30"	34"	None	WSA1019	WSA2019	WSA3019	WSA5019
			Back and side stops	WSA1020	WSA2020	WSA3020	WSA5020
72"	30"	34"	None	WSA1023	WSA2023	WSA3023	WSA5023
			Back and side stops	WSA1024	WSA2024	WSA3024	WSA5024
72"	36"	34"	None	WSA1027	WSA2027	WSA3027	WSA5027
			Back and side stops	WSA1028	WSA2028	WSA3028	WSA5028

NOTE For a mobile work station, change the "A" to "W" in product numbers.

Example: WSW2019

Model including:
Your choice of top _____
Your choice of top accessories _____
2 legs 27"d × 32"h _____
2 shelves 12"d _____
1 stringer _____
Model number with the drawer unit shown: WSC0107

Mobile Model (total height 35") including the following extra accessories:
2 pairs of caster adaptors _____
1 pair of rigid casters _____
1 pair of swivel casters with total brake _____
Note: leg height is 28" for mobile models.



WSC0109

Closed model

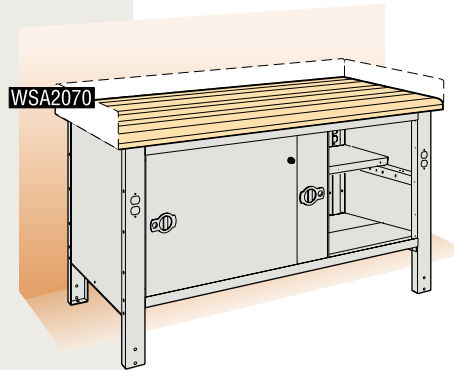

WSA2070

Dimensions			Work area accessories	Type of top			
width	depth	height		Steel	Laminated wood	Plastic laminate	Wood composite
60"	30"	34"	None	WSA1070	WSA2070	WSA3070	WSA5070
			Back and side stops	WSA1076	WSA2076	WSA3076	WSA5076
72"	30"	34"	None	WSA1071	WSA2071	WSA3071	WSA5071
			Back and side stops	WSA1077	WSA2077	WSA3077	WSA5077
72"	36"	34"	None	WSA1072	WSA2072	WSA3072	WSA5072
			Back and side stops	WSA1078	WSA2078	WSA3078	WSA5078

NOTE For a mobile work station, change the "A" to "W" in product numbers.

Example: WSW2070

Closed model including:
Your choice of top _____
Your choice of top accessories _____
2 legs 27"d × 32"h _____
Sliding doors with lock _____
2 side panels and 1 back panel _____
3 shelves 12"d _____
2 leg cross bars _____